

Accelerometer AC Power Supply System

9011

- **High-Definition Waveform Generators**
 - 0.005% Total Harmonic Distortion
 - 0.001° Phase Resolution
- **High-Power Low-Distortion Amplifiers**
 - 10V_{rms} or 50V_{rms} (option)
- **Complete Set of Tools**
 - Waveform Creation Software
- **Systems Ready**
 - External Reference Synch
 - Internal Crystal Reference
 - GPIB
- **Value and Invaluable Support**
 - Best Value and Outstanding Support

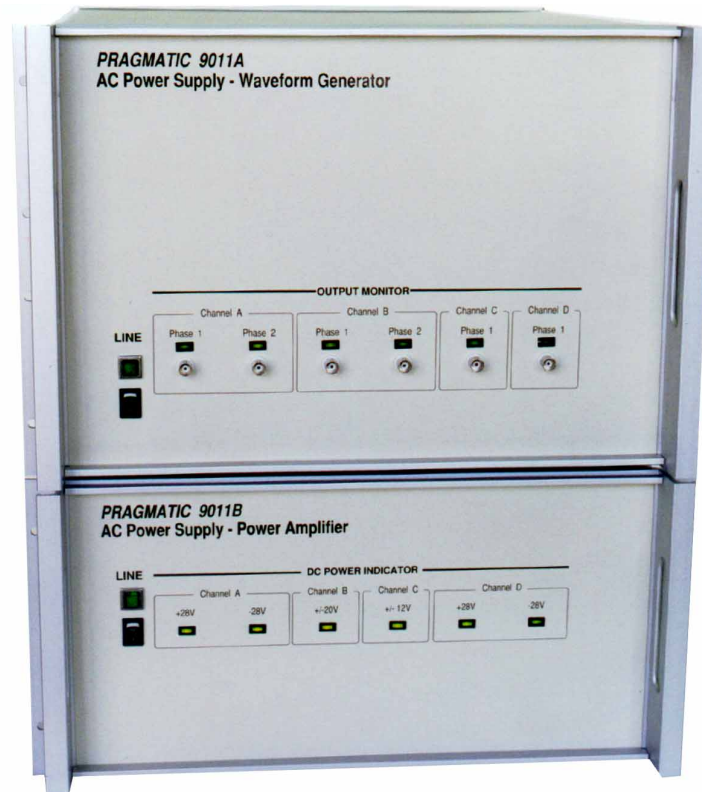

The Pragmatic AC Power Supply System is a highly stable, low-distortion, high-power, multi-channel signal source designed to test gyroscope accelerometers. Phase-to-phase stability of 0.1 degree is an outstanding feature of the system. Phase adjustment resolution is 0.001 degree and is digitally controlled. Frequency stability is assured because the output is crystal-referenced. Alternatively, each channel may be locked to an external reference signal. Output

frequencies range from 30 Hz to 50 kHz and the sinewave distortion is 0.05 percent. Likewise, the system is amplitude-stable and offers 0.1 percent settability.

A typical system consists of a 9011A Waveform Generator and a 9011B Power Amplifier each providing six flexible output channels. The channels may be operated in pairs or individually. The waveform generator may be programmed to output sinewaves, squarewaves or any arbitrary waveshape. Amplifier gain is

fixed and the signal amplitude is set at the waveform generator.

All six channels are remotely programmed using IEEE-488.2 (GPIB). Each channel may be programmed in frequency, phase offset and amplitude. Waveforms may be created in and downloaded from Pragmatic's Windows-based waveform creation software, WaveWorks Pro. The versatility of the 9011 accommodates complete parameter controls to meet all test requirements.

System Block Diagram

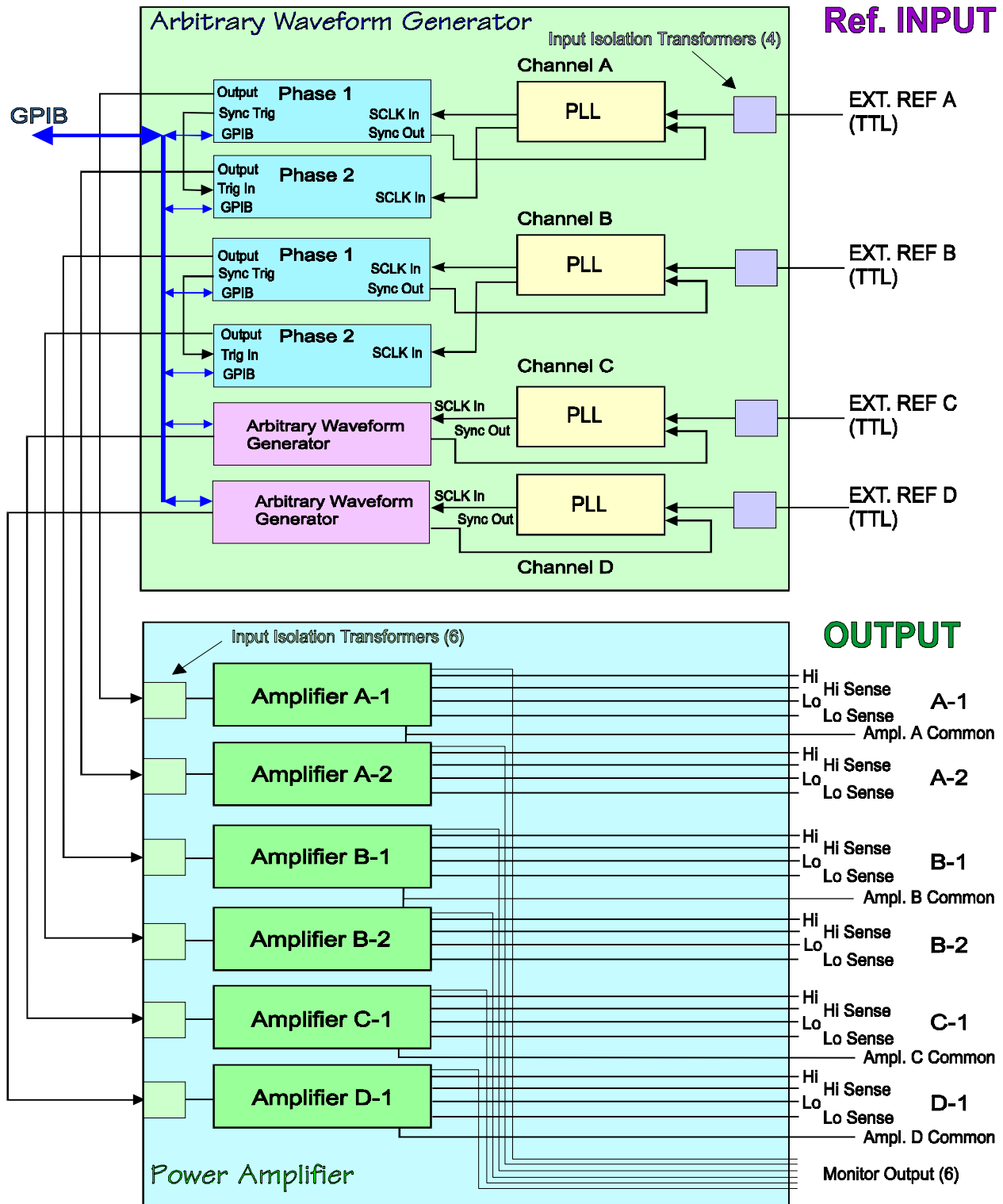

9011 System Description

The System Block Diagram - AC Power Supply, illustrates the interconnections between the major components of the system and indicates the functional interrelationships between the components. A typical setup consisting of two dual-channel sets and two single-channel sets are shown, although any arrangement of the six channels is permissible. The two dual-channel sets are identified as Channel A and B respectively. The two single-channel sets are identified as Channel C and D respectively. These labels are retained throughout the entire system.

For the application shown, each channel set consisting of one or two phases is synchronized to an external TTL reference signal. This approach allows the system to be locked to the specified external timing. The function of the phase-lock-loop (PLL) is to set up the clock frequency required by the arbitrary waveform generator (AWG) which will produce the precise frequency being presented at the external reference input. Optionally, the individual AWG associated with each of the phases may be controlled from the internal sample clock (SCLK). In this case, the frequencies are referenced to an internal crystal. However, for the dual-channel configuration, only the MASTER phase sample clock is locked to the reference. This sample clock is also furnished to the SLAVE which guarantees synchronous timing.

Each one of the phase AWGs outputs a low-distortion sinewave achieved by using 16-bit resolution digital-to-analog converters. This signal is filtered to eliminate the unwanted sample-clock-related frequency components resulting in output sinewave signal distortion of less than 0.05%. A second benefit provided by

the AWG is the ability to mathematically compute the phase-shifted waveshape. Using this waveform description, precise phase control is provided by the 16-bit resolution AWG. Likewise, stability is assured because the system is digital.

The power amplifiers for all channels are similar and may be optimized for current limit setting and gain. In general, the system provides 15 watts output power per channel. A unique remote sense system is provided to assure signal quality and level at the load. This is achieved by a 4-wire Kelvin connection between the source and the load for each channel.

In general, all related components in each of the channels are interchangeable to offer convenient maintenance. The system is compact, flexible and versatile, and each channel is individually programmed in frequency, amplitude and phase.

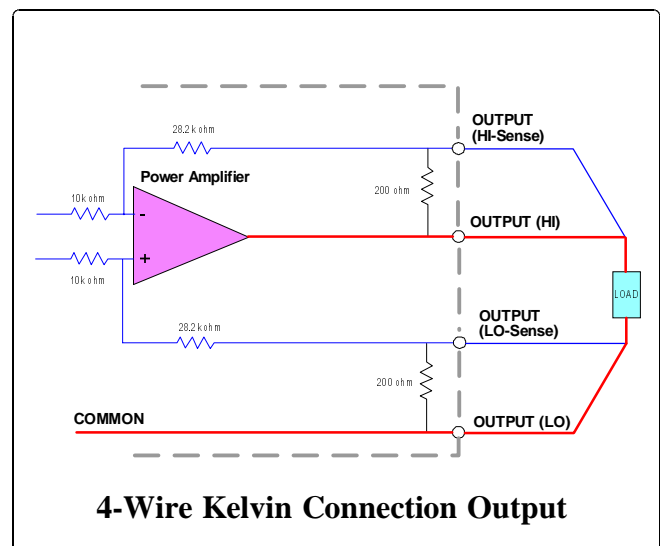

Accelerometer AC Power Supply System

9011

Electrical Specifications

Description	Standard Output Power	High Output Power
Voltage Range (Vrms)	2.00~10.00	10.0~50.0
Voltage Adjust (Vrms)	0.01	0.05
Voltage Stability (% 24 hrs)	≤ 0.1	≤ 0.1
Voltage Difference (mVrms)	50	100
Sine Distortion (%)	≤ 0.1	≤ 0.15
Frequency Range (Hz)	30~50k	50~30k
Current (A pk per phase)	1.0	0.5
Phase Offset (Degree)	90±0.5	90±0.5
Phase Stability (Degree)	≤ 0.1	≤ 0.1
Output to Ref. Signal Phase (Degree)	0±0.5	0±0.5
Output Power (Wmax/phase)	7.0	17.5

Signal Isolation

External Frequency Reference: TTL, transformer coupled
Power Amplifier Input: Transformer coupled

System Configuration

Number of Channels:	6
Output Signal Monitor (per channel):	1
Output Signal Connector:	Rear Panel
Output Sync Signal:	Rear Panel
Output Signal Indicator (per channel):	1
Power Amplifier Indicator (per channel):	1

Computer Interface

GPIB: IEEE 488.2-1987

Programmable Parameters

Frequency:	Nominal Channel Frequency ± 10% with 0.1% resolution External Channel Reference Frequency
Amplitude:	100% of Specified Range with 0.1% resolution
Output:	On or Off
Waveform:	Standard or User-Defined

Waveform Creation Tools

Software:	WaveWorks Pro
Operating System:	Windows 98, 95 or 3.1
Computer Requirement:	486DX or better with 4MB RAM space
Interface Card:	National Instruments® AT-GPIB/TNT Card (or equivalent)

Environmental

Operating Temperature:	0°C to +40°C, ambient
Specified Accuracy:	+23°C ±3°C
Storage Temperature:	-20°C to +60°C
Humidity Range:	80 % R.H.

General

Mains:	100/120/220/240 VAC, 5% -10%; 48 ~ 63Hz
	Waveform Generator (9011A) Power Amplifier (9011B)
Power Rating:	240VA (175W) 960VA (700W)
Dimensions (H x W x L):	12.25" x 19" x 21" 8.75" x 19" x 21"
Weight (approximate):	75 lbs (34 kg) 95 lbs (43 kg)

Weight and dimensions are approximate. Errors and omissions excepted. Prices and specifications subject to change without notice.

Pragmatic is a registered trade mark of Pragmatic Instruments, Inc. National Instruments is a registered trade mark of National Instruments Corporation.

© Copyright 1999 Pragmatic Instruments, Inc. All rights reserved.

PRAGMATIC[®]
INSTRUMENTS, INC.

7313 Carroll Road, San Diego CA 92121-2319 • Tel. (858) 271-6770 • Fax (858) 271-9567

Toll Free (800) PRAGMATIC or (800) 772-4628

E-mail awgsales@pragmatic.com Web <http://www.pragmatic.com>